

Choosing a Ham Radio

Your guide to selecting the right equipment

Lead Author—Ward Silver, N0AX;

Co-authors—Greg Widin, K0GW and David Haycock, K16AWR

Table of Contents

- Introduction
- Quick Start
- Square One
- VHF/UHF
- HF
- Manufacturer's Directory

WHO NEEDS THIS PUBLICATION AND WHY?

Hello and welcome to this handy guide to selecting a radio. Choosing just one from the variety of radio models is a challenge! The good news is that most commercially manufactured Amateur Radio equipment performs the basics very well, so you shouldn't be overly concerned about a "wrong" choice of brands or models. This guide is intended to help you make sense of common features and decide which are most important to you. We provide explanations and defini-

tions, along with what a particular feature might mean to you on the air.

This publication is aimed at the new Technician licensee ready to acquire a first radio, a licensee recently upgraded to General Class and wanting to explore HF, or someone getting back into ham radio after a period of inactivity. A technical background is not needed to understand the material.

ABOUT THIS PUBLICATION

After this introduction and a "Quick Start" guide, there are two main sections; one covering gear for the VHF and UHF bands and one for HF band equipment. You'll encounter a number of terms and abbreviations--watch for *italicized* words—so two glossaries are provided; one for the VHF/UHF section and one for the HF section. You'll be comfortable with these terms by the time you've finished reading!

We assume that you'll be buying commercial equipment and accessories as new gear. Used equipment is cheaper, of course, but may have faults or defects with which you might be unfamiliar, leading to problems. Teaming up with an experienced ham or a reputable dealer is the way to evaluate used equipment. Unless you are experienced with electronics, kits and homebuilt rigs are not recommended as a first radio, either. The Web sites for manufacturers of Amateur Radio equipment are listed at the end.

What This Publication Is Not

This isn't a traditional "buyer's guide" with feature lists and prices for many radios. Manufacturer's Web sites and catalogs from radio stores have plenty of information on the latest models and features. You won't find operating instructions or technical specifications here – download brochures and manuals directly from the manufacturer!

Your Best Resource

Your best resource is a knowledgeable friend. Better yet, how about a group of friends? This is where a ham radio club or team can really help. Find local clubs via the ARRL's home page: www.arrl.org—enter "Clubs" in the site's search window. A club can help you with every aspect of choosing a radio; from explaining a feature to filling you in on

what works best in your area. These helpful *Elmers* (ham radio mentors) may be willing to loan or demonstrate a radio so you can experience different styles of operating before making buying decisions. If the group is supporting a public-service activity, such as a walkathon, parade, or race, volunteer to help so you can see how the radios are actually used.

The “Choosing a Ham Radio” Web Site

It’s not possible to give you all the details in one publication, so a supporting Web page has been created at www.arrl.org/choosingaradio. It is referenced on a Web page for new hams www.arrl.org/newham that includes handy references to download and print, supplements that will be updated, and links to a more complete glossary and other online resources and books to help you learn even more.

NEW TO HAM RADIO?

If you are new to ham radio with a background in other types of radio communications, you should read the supplement “Ham Ways – A Primer” available at www.arrl.org/newham/HamWaysPrimer.pdf. It will explain some of the ways hams communicate that may be unfamiliar. This will help you understand more about ham radio features and why they are important to hams.

ARE YOU READY?

Finally, savor the experience—you’ll never buy another “first” radio, so have fun! If things don’t turn out exactly as you expect, you can easily sell or trade for different equipment. Most hams try many radios and you probably will, too. So relax and prepare to enjoy the ride! Once you’re finished, others can use this publication, too. Give it away or tell them about this guide’s Web site where they can download and print their own copy!

CONTRIBUTORS

The following Elmers contributed by reviewing this publication to make it as useful as possible, their way of giving back to ham radio: Norm, K6YXH; Ken, WA3KD; Dave, KA1HDG; Mike, N4FOZ; James, KG8DZ; Jason, KI6PCN; Barb, N6DNI; Patrick, KI6PCS; Ken, WD9DPK; Mary, KI6TOS; Paula, KI6SAK; Jack, AD7NK; Katie, W1KRB; Sharon, KE7HBZ; Matt, N8MS; Marty, N6VI; Diane, KE7PCS; Charles, KE4SKY and Chris, KB7YOU.

WHAT DO YOU WANT TO DO?

Answering that question starts with the type of activities that interest you, such as emergency communications (“emcomm”), casual conversation with friends or club members, or communicating using digital data. You’ll need to then consider the range over which you expect to make contacts and the type of station you expect to use.

Table 1

Bands and Typical Distances

Range	Bands
Nearby	VHF/UHF
Regional	VHF/UHF (via repeaters) and HF (direct contact)
Country-wide	HF
World-wide	HF (direct contact), VHF/UHF (Internet links)

Where Are The Hams You Want To Contact?

Considering how radio waves of different frequencies propagate (travel) helps answer the question of what bands your radio will need. Different bands support different ranges of contacts as shown in **Table 1**. Evaluate the activities in which you want to participate to see where you will need to make contacts. (Glossaries in the *Ham Radio License Manual* or on-line at www.arrl.org explain these and many other terms.)

Quick Start: Common Profiles

You may find it useful to start with one of our four common ham “profiles”. Your operating needs could be similar to one of them. Once you choose a profile, fill in the details by reading the VHF/UHF or HF sections that follow for details on the various features and functions. Download the comparison form at www.arrl.org/choosingaradio/compare to organize your shopping list.

Consult local hams to find out what bands are used most commonly. For example, in more sparsely populated areas, the 70 cm band may not be in widespread use. In other areas, another VHF or UHF band – such as 222 MHz – may be in regular use.

Emergency Communication (Emcomm) Team Member or Personal Emergency Communications

For operation through easily accessible repeaters or over very short ranges, you’ll need a VHF/UHF (dual-band) handheld radio with at least 50 memories and 3 to 5 watts of output power. A spare rechargeable *battery pack*, a pack that holds AA or AAA batteries, an automotive adapter, and a desktop *quick-charger* are must-have accessories. For operation without repeaters or through distant repeaters while mobile or in remote areas, add a VHF/UHF mobile radio with an output of 25 watts or more and a dual-band quarter-wave mobile whip antenna. Many hams have one of each type of radio.

Beginning Home HF Operation

HF transceivers with 100 watts of output and a built-in *antenna tuner* make an excellent entry-level radio. HF radios with VHF and even UHF coverage are available at higher cost. If the radio can’t operate directly from ac power you’ll need an external dc *power supply*. A multi-band dipole is an excellent and inexpensive antenna, connected to the radio through coaxial cable or open-wire feed line—the latter will require an external antenna tuner. With some compromise in performance, a multi-band, ground-independent vertical antenna is easy to set up and requires coaxial cable to connect to the radio. To try Morse code, add a straight key or *paddle* (most radios have a built-in *keyer*). To operate using digital modes, add a sound card *data interface* with cables made to connect to your radio.

Casual Local or Regional Operating

Start with a VHF/UHF mobile radio with an output of 25 watts or more. For mobile operation, add a dual-band quarter-wave mobile whip antenna. At home, a mobile antenna can be used indoors or a dual-band base antenna can be mounted outside, using coaxial cable to connect the radio and antenna. For operation from ac power, a power supply capable of supplying the radio’s specified current consumption is required. If you need more portability, add a VHF/UHF handheld as a second radio—it is common (and practical) to have both types of radio.

Portable or Mobile Operating – All Bands

This type of operation is best supported with an “all-band, all-mode” mobile-sized transceiver that covers the HF and VHF bands, plus the 70 cm band in some models. You’ll need two types of antenna; a dual-band quarter-wave mobile whip antenna for 2 meters and 70 cm (there are also tri-band antennas that include 6 meters), and a mobile HF antenna. A permanent or magnetic mount with one or more interchangeable single-band HF whip antenna is a good way to try operating from your vehicle.

Types of Operation

Base or Fixed (a permanent location)
Mobile (in a vehicle)
Portable (temporary installation)
Handheld (carried by hand, pocket, or belt clip)

From Where Will You Be Operating?

Radios are designed with sets of features that favor the types of use listed at the side of this page, although they can be used in more than one way. Considering the circumstances in which you expect to do most of your operating and the ranges at which you expect to make contacts will help you decide what type of radio is right for you.

Radios designed for *base* or *fixed-station* are the most capable and powerful. They are also bigger and their standby power requirements are higher. Many of the manufacturers of base-type radios also offer smaller, lighter models for *portable* operating in tight quarters, from a vehicle, while camping or otherwise away from home and with limited power availability. These radios generally don't have the same level of performance or as many front-panel controls as base station models. A *mobile radio* is one intended for use in vehicles, usually on FM voice in the VHF and UHF bands. Mobile "rigs" with a dc power supply make a good VHF/UHF FM voice base station, too. *Handheld* radios are intended to be carried while in use, operate from rechargeable battery packs, and have FM voice transmitter outputs of a few watts on the VHF and UHF bands.

Ready, Set, Go!

Begin by reading this guide from start to finish, even if you think you already have a good idea of what radio you want. You might find some material that changes your thinking a little bit, possibly saving you some money or increasing your long-term satisfaction with the equipment you select! Once you've finished, focus on the frequency bands (VHF/UHF or HF) and type of operating (base, mobile, portable, or handheld). Then make your list of "must-haves" and "nice-to-haves" (useful features that aren't absolutely necessary). Armed with catalogs and a Web browser, you're ready to start shopping or take in a *hamfest* (a ham radio flea market and convention)! A blank form to help you compare different radios is available for downloading at www.arrl.org/choosingaradio/compare.

VHF/UHF EQUIPMENT

The VHF and UHF bands above 30 MHz are available to all classes of ham licensees and are widely used for local and regional contacts. The majority of activity uses FM voice on repeaters and simplex channels at the higher frequency segment of each band. The lowest frequency segments in each band are set aside for *weak-signal* operating where longer range contacts are made using SSB voice and Morse code. (SSB and Morse offer better performance than FM for contacts made over long distances without the aid of a repeater to relay weak signals.) In adjacent segments you'll also find Amateur Radio satellite signals and data communication using digital modes, among other activities.

For FM voice in an area with good repeater coverage, a handheld radio provides the maximum flexibility in operating—from home, a vehicle, or while on foot. It's more practical, however, to purchase a higher-powered mobile radio that can be used at home, too. Most hams have a mobile radio in their vehicle plus a handheld radio for portable operation.

If you are going to operate primarily from home, an *all-mode* radio designed for fixed- or base station use may be a better choice. While larger and more expensive than mobile and handheld radios, they also operate on SSB and CW (Morse code) and offer better receiver performance, larger displays, and easier access to many controls and functions.

VHF/UHF GLOSSARY

- Airband:** VHF channels for aviation air-to-air and air-to-ground communications
- All-mode:** radio that can operate on AM, SSB, CW, digital modes and FM
- APRS:** Automatic Position Reporting System
- ARES®:** Amateur Radio Emergency Service, sponsored by the ARRL's Field Organization
- Attenuate (attenuation):** reduce in strength
- Auto-patch:** connection ("patch") between a radio and the telephone system
- Automotive adapter:** device that plugs into a vehicle lighter socket and supplies power to a radio or electronic device
- Battery pack:** several battery cells connected together to act as a single, larger battery
- Beam:** antenna with gain primarily in one direction
- Charger:** device for recharging batteries
- Cloning:** duplicating the memory contents of a radio in another radio
- Cross-band:** receiving on one band and transmitting on another
- CW (Continuous-wave):** Morse Code
- dB (decibels):** logarithmic method of comparing two signal strengths (power, voltage, current)
- Digital mode:** communication method that exchanges characters instead of voice or CW
- DTMF:** Dual-Tone, Multi-Frequency, signaling tones ("TouchTones®") used by telephone systems
- Duplex:** transmitting on one frequency and receiving on another in the same band
- Emcomm:** abbreviation for "emergency communications"
- Energy density:** amount of energy a battery stores per amount of weight or volume
- Feed line:** cable used to transfer radio-frequency energy
- FRS:** Family Radio Service, short-range handheld radios that can be used without a license
- GMRS:** General Mobile Radio Service, a no-test licensed service in the UHF range for family use
- Gain (antenna):** antenna's ability to concentrate received or transmitted energy in a preferred direction
- Ground-plane:** conductive surface that acts as an electrical mirror. A ground plane antenna is an antenna that requires a ground plane to operate
- HF:** High Frequency (3- 30 MHz)
- Impedance:** opposition to ac current flow by a circuit, feed line, or antenna
- IRLP:** Internet Repeater Linking Project, a system of accessing and linking repeaters through the Internet
- MARS:** Military Affiliate Radio System in which hams communicate with military stations
- Menu:** list of selectable control or configuration functions or options
- Monitor:** listen without transmitting or disable a radio's squelch to listen for weak signals
- Mount (mag, trunk, lip, mirror):** a method of attaching an antenna to a vehicle
- Overload:** signal so strong that circuits begin to operate improperly
- Packet:** amateur digital data system that communicates using VHF and UHF frequencies
- Polarization:** orientation of radio waves with respect to the surface of the Earth (vertical, horizontal polarization)
- Power supply:** device that changes ac power into dc power
- Range:** distance over which communication can take place
- Rotate (batteries):** to take in and out of service, preventing continuous use
- Scanning:** monitor a range of frequencies or a set of memory channels for activity
- Simplex:** transmitting and receiving on the same frequency
- Shortwave:** see *HF*

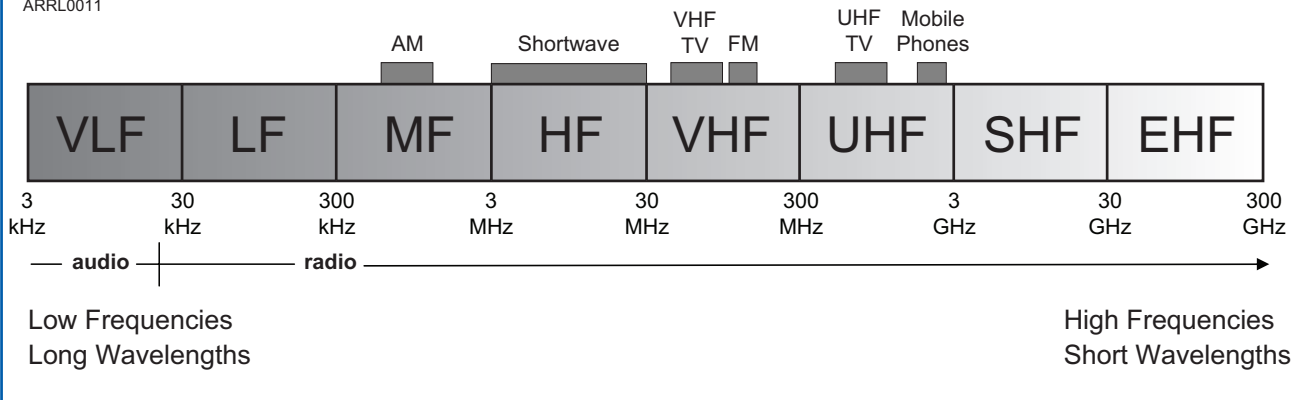

Sub-audible: audio frequencies below the usual communication range of 300 – 3000 Hz

Trunking (trunked) systems: VHF/UHF systems used by commercial and government agencies, sharing a few channels among many users by using computers to control the radio's frequencies

UHF: Ultra High Frequency (300 MHz – 3 GHz)

VFO: Variable Frequency Oscillator, refers to a radio's continuous tuning mechanism

VHF: Very High Frequency (30 MHz – 300 MHz)

Wall wart: light-duty power supply plugged directly into the an ac outlet

Whip: antenna made from a long, thin metal rod

Winlink (Winlink 2000): system for sending and receiving email via Amateur Radio

FREQUENCIES AND MODES

If your interest lies primarily in using the local FM repeaters and simplex channels, information about what frequencies are most used is available from local radio clubs and newsletters, the local frequency coordinator's Web site, the *ARRL Repeater Directory* (www.arrl.org/catalog), and *emcomm* teams. Ask about the coverage (*range*) of the repeaters, as well.

The most popular VHF/UHF radios for FM voice and data are *dual-band*, meaning that they can transmit on both the 2 meter (144-148 MHz) and 70 cm (420-450 MHz) bands. Higher-end units allow you to monitor several bands at once and listen on one band while transmitting on the other.

Whether you need the radio to cover the 50 MHz, 220 MHz or 1.2 GHz bands will depend on activity in your area. The first two are often used

by *emcomm* teams and the last is more likely to be used in densely populated areas. *Cross-band* repeater capability (receiving on one band and retransmitting the signal on the other band) is a "nice-to-have", but not commonly needed.

Receiver coverage comes in three flavors. "*Ham band receive*" can tune all of the ham bands, plus narrow ranges above and below the band edges for amateur auxiliary services, such as MARS. "*Extended receive*" includes reception of selected frequency ranges such as those in **Table 2**. "*Wideband receive*" covers a wide range of continuous frequencies—good for using the radio as a scanner. Being able to receive commercial broadcasts and non-ham services is very helpful during emergencies although this capability may make the receiver more susceptible to overload and interference from strong nearby transmitters.

Table 2

Useful Non-Amateur Bands

AM Broadcast	550 kHz – 1.8 MHz
Shortwave Broadcast	3 MHz – 25 MHz
Low-band VHF	30 – 50 MHz
FM Broadcast	88 – 108 MHz
Aviation (AM & FM)	118 - 144 MHz
High-band VHF	148 – 174 MHz
Marine	156 – 158 MHz
NOAA Weather	162.4 – 162.55 MHz
Military Aviation	225 – 389 MHz
Government	406 – 420 MHz
UHF	450 – 470 MHz

Caution - even though some amateur radios have the ability to receive AM broadcast, *shortwave broadcast* (SW BC) and aviation AM signals, most cannot receive SSB or CW signals and thus are unsuitable for use on the HF ham bands. Receiving VHF AM aviation signals (sometimes called *airband*) is also handy for tracking down and identifying sources of interfering noise, such as from power lines or appliances. You can find out more about what stations are on what frequencies by browsing online frequency lists such as www.panix.com/clay/scanning/freq-lists.html.

Many municipal and government systems use *trunking* systems in the VHF and UHF bands. (Trunking systems share a few channels among many users by changing the frequency of individual radios under the control of a central station.) These can not be received by ham radios or scanners without trunking features.

POWER – INPUT AND OUTPUT

Transmitter output power is crucial to successful communication because, along with antenna choice, it affects communications range. Check with local hams about the power levels required to “hit” (access) popular repeaters and for effective simplex contacts. The local terrain should be considered—flat, open areas require less power. A handheld radio should be capable of 3 to 5 watts of output for consistent coverage. Mobile radios (10 – 50 watts) have far better coverage, but require more current, such as from a car battery or power supply. Most radios have variable power settings to conserve power and battery capacity.

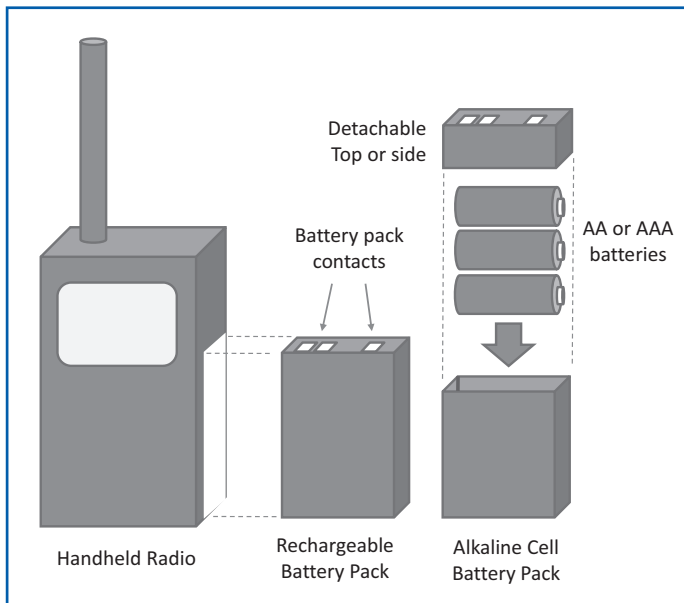

Figure 1 — Handheld radios use sealed and rechargeable multi-cell battery packs that fit a specific radio and are rarely interchangeable between models.

Handheld radios use sealed and rechargeable multi-cell *battery packs* that fit a specific radio and are rarely interchangeable between models. It is wise to purchase a spare pack and *rotate* the packs regularly. Packs that hold regular alkaline AAA or AA cells are important to have for operation away from home or in emergencies when recharging power may not be available. (Remember to dispose of dead and weak battery packs properly!) Several battery options are described in **Table 3**.

The higher a battery’s *energy density*, the longer a battery of a given size will last. Energy density drops with temperature, so a cold battery won’t deliver as much energy as one at room temperature. Most batteries are rated to be stored at temperatures from -20 to +45° C.

Handheld radios are sold with a wall-mounted supply or “*wall wart*” that charges the batteries slowly. This may be inconvenient during emer-

Table 3
Types of Batteries and Battery Packs

<i>Technology</i>	<i>Energy Density</i>	<i>Limitations</i>	<i>Cost</i>
Ni-Cad	Low	Low energy ratings	Low to medium
Ni-MH	High	Tend to self-discharge	Medium
Li-Ion	Highest	Tend to self-discharge	Medium to High
Alkaline	High	Not rechargeable	Low

gency or heavy use. A *desk* or *drop-in charger* charges the packs quickly and holds the radio upright. If the radio can charge from 12 V, it can also be charged in a vehicle with an *automotive adapter*. An automotive adapter that allows your handheld radio to charge (and possibly operate) from a vehicle's cigarette lighter or other 12-volt source is useful if ac power is unavailable. Not all handheld radios can transmit while connected to chargers—be sure to check the manual!

Radios for base, portable, or mobile use require an external power source. This may be a vehicle's electrical system, a deep-cycle battery, or an ac-operated power supply. Mobile radios may require up to 20 amps on transmit at full power, so be sure your power source can deliver enough current.

Power supplies and the cables used to connect the radio must be able to supply the maximum required current for your radio at the proper voltage. Check the radio's specifications for input current to find out how much current is needed. The radio manual should also specify what wire size for a given cable length is needed to insure adequate voltage at the radio under full load.

SQUELCH AND TONES

Squelch is the circuitry in FM radios that prevents the user from having to listen to noise or unwanted signals by muting the radio's audio output unless the proper type of signal is received. The radio's manual will explain how to use a squelch level control knob (like the typical knob in the illustration) or *menu* setting, common on pocket-sized handhelds. These are the different types of squelch and associated features:

- *Carrier squelch*, the simplest and most common type of squelch, mutes the radio when no signal stronger than a preset settable threshold is present.

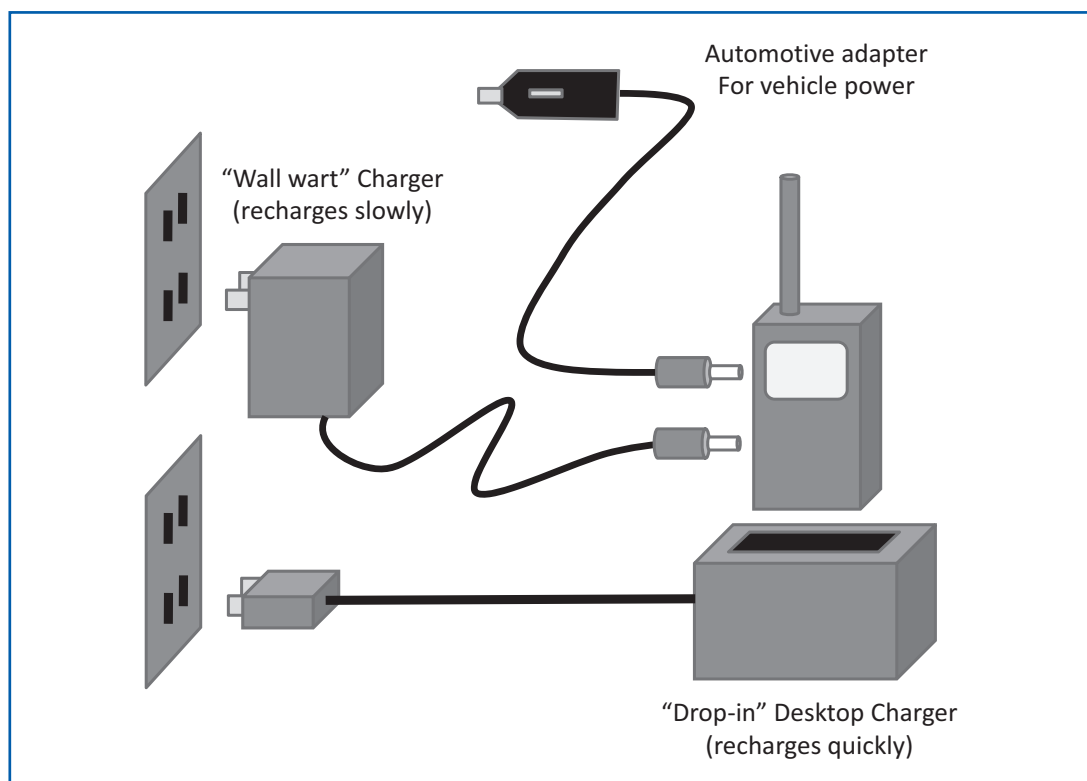

Figure 2 — Handheld radios are sold with a wall-mounted supply or “wall wart” that charges the batteries slowly. A *desk* or *drop-in charger* charges the packs quickly and holds the radio upright. If the radio can charge from 12 V, it can also be charged in a vehicle with an *automotive adapter*.

- *Tone receive squelch* requires a specific *sub-audible* tone for the received audio to be heard, as when accessing a repeater. This keeps you from hearing other users on the same frequency, just like “privacy codes” on the popular handheld radios that use the FRS and GMRS channels. (You still have to listen to the channel before transmitting.)

- *Digital Coded Squelch (DCS)* – a short sequence of tones must be received at the beginning of each transmission before turning on the output audio. DCS is used by groups sharing a frequency so that they only hear audio from other group members. (Like tone-receive squelch, listen before transmitting.)

- *Call sign squelch* – digital systems, such as D-STAR, send the call sign of the receiving station along with the transmitted signal. The station called will then be alerted to the incoming call.

- *Attenuation* – some radios *attenuate* the received signal when the squelch threshold is set to high levels. This reduces interference from *overload* interference where strong paging and commercial signals are present.

- *Monitor* – an FM radio’s *monitor* button or key temporarily defeats or “opens” the squelch so that you can hear any station using the channel. This is used to listen for weak signals or for other stations before transmitting.

All new radios can generate sub-audible repeater access tones. (These are also called PL™ or CTCSS tones.) Some have a feature called *tone scan* that enables the radio to determine what access tones a repeater requires by listening to the stations using it. This is very useful when traveling or accessing an unfamiliar repeater.

- *DTMF* or *Touch Tone*™ dual-frequency tones are used to dial phone numbers through a repeater’s *auto-patch* or to enter IRLP and Echolink access codes. A radio’s ability to store and play back sequences of DTMF tones saves a lot of time when using either service.

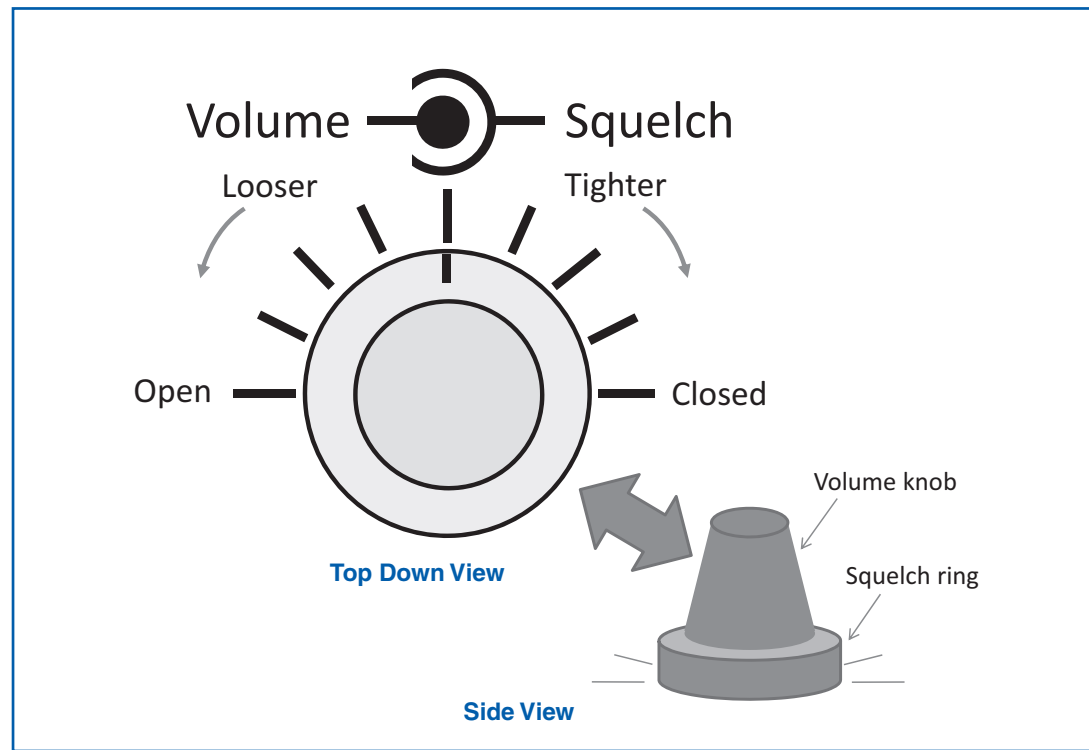

Figure 3 — Squelch is the circuitry in FM radios that prevents the user from having to listen to noise or unwanted signals by muting the radio’s audio output unless the proper type of signal is received.

MEMORIES AND VFOS

Ads for radios tout the number of *memory channels* or *memories*—each can store the complete radio configuration to access a favorite repeater or channel. Having lots of memories means you can dedicate a group to your most-used repeaters and simplex channels while other groups can be used for channels you use for special events, training, and vacation or travel.

How many do you really need? Start by making a list of all local and regional repeaters and simplex channels on the bands covered by your radio. (A club or ARES team can be quite helpful in making the list.) If your radio has wideband- or extended-receive, add some AM and FM broadcast stations and the primary frequencies used by public safety and service agencies in your area. Don't forget the NOAA weather stations and if you are near water, the common VHF marine channels. Increase that total by about one third and you have a pretty good idea of how many memories you'll need.

Some memory channels have special functions. *Call channels* provide easy recall of your favorite channels. *Scan control* channels store frequency limits for scanning functions, if your radio can act as a scanner.

The ability to receive on two channels at once (“*dual receive*”) is very useful. “*Priority channel*” and “*Channel watch*” monitor a channel for activity at all times and switch to that channel when a signal is present. This is useful during emcomm and public service activities or if you want to monitor a “home” repeater while operating elsewhere.

All radios have at least one VFO that tunes to any frequency the radio covers. VFOs

on FM-only radios usually tune in discrete steps (e.g., every 2.5, 5 or 10 kHz) rather than continuously. On radios with more than one VFO, each can separately set the access tone, transmit offset, and other operating parameters. Once a VFO is configured, the information is transferred or *programmed* into (stored in) a memory. VFOs can act as temporary memories, too. A second VFO is a “nice-to-have” for flexibility.

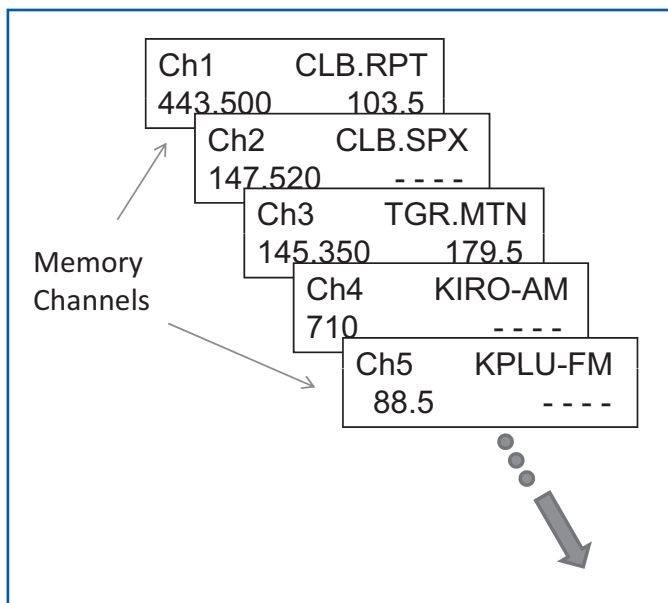

Figure 4 — Memory channels or memories can store the complete radio configuration to access a favorite repeater or channel.

PROGRAMMING MEMORIES

Look in the radio's manual at the method used to program the VFO's information into a memory channel. You may find that some methods are easier to remember or perform. Some radios may have a *quick-program* function that quickly stores the VFO settings in an un-programmed memory. Alphanumeric channel labels (such as “CLB_RPT”) make it much easier to remember which channel is which. (See the section on “Programming and configuration software” for more information.)

Digital modes

Exchanging text, email, graphics, and files is an important part of today's emcomm and other applications of radio. The modes that transmit and receive data are referred to as *digital modes*. On VHF and UHF, the most common digital mode is *packet radio* or “packet”. (tapr.org/packetradio.html) The name comes from data being transmitted in groups of characters that are called *packets*. Packet is also known as AX.25, the designator of the technical standard that describes it. To use packet, you'll need an FM radio, a

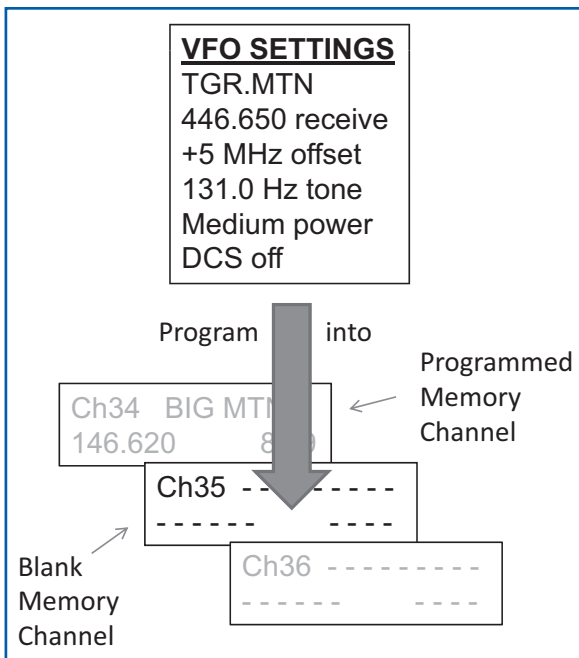

Figure 5 — Once a VFO is configured, the information is transferred or programmed into (stored in) a memory.

special interface called a *terminal node controller* (TNC), and a computer as shown in **Figure 6**. Some radios have TNCs built in.

Packet provides “keyboard-to-keyboard” communication a bit like instant messaging. It is also used to send email from your computer via *Winlink* system mailboxes. The *Automatic Position Reporting System* (APRS - www.aprs.org) uses packet radio to report your position and other information over the Internet. A few radios have features designed for use with APRS, such as special text displays, a data interface to communicate with a GPS receiver, or built-in GPS receivers.

Packet commonly operates at two speeds; 1200 bits/second (bps) and 9600 bps (about 120 and 960 characters/second, respectively). At the slower speed, the TNC converts characters from the computer’s serial or USB port into audio tones fed to the radio’s microphone input. Any FM voice radio is suitable for packet radio use at 1200 bps.

To operate at the higher data rate, the radio must have a special connection specifically for use with digital modes. 9600 bps is more demanding of the radio and not all radios work well at that speed. Check the radio’s specifications to see if it is rated for 9600 bps data. Un-

less you specifically need to use high-speed data communication, you don’t need 9600 bps capability. Most packet operation takes place at 1200 bps.

D-STAR is a new digital data system based on a standard from Japan. Equipment is currently available from Icom (icomamerica.com/en/products/amateur/dstar) along with some third-party adapters. D-STAR radios can talk directly to each other or through networks of repeaters linked over the Internet. On 2 meters and 70 cm, D-STAR radios provide a low-speed data connection (about 80 bps) directly from the radio to your computer’s USB or serial port—no TNC is required. On 1.2 GHz, D-STAR radios provide a network-style Ethernet connection to your computer, compatible with Web browsing and other Internet applications. The speed is about the same as the fastest 56 kbps dial-up connections.

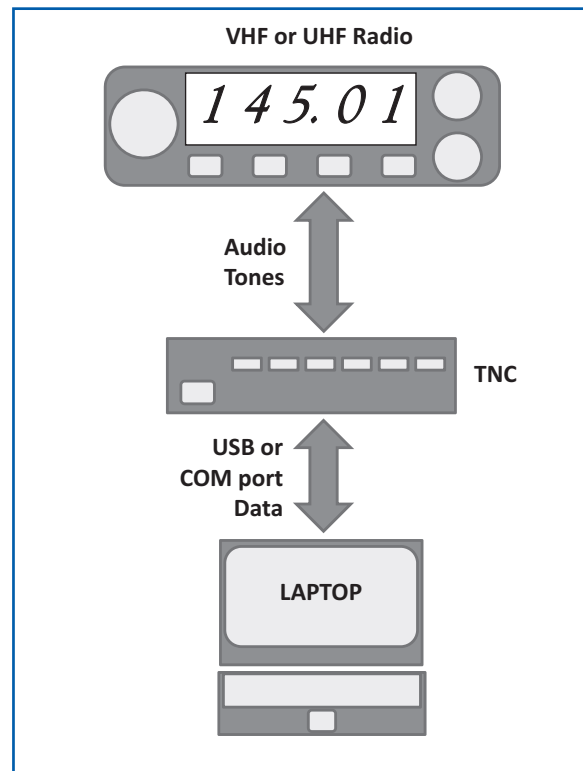

Figure 6 — To use packet, you’ll need an FM radio, a special interface called a *terminal node controller* (TNC) and a computer.

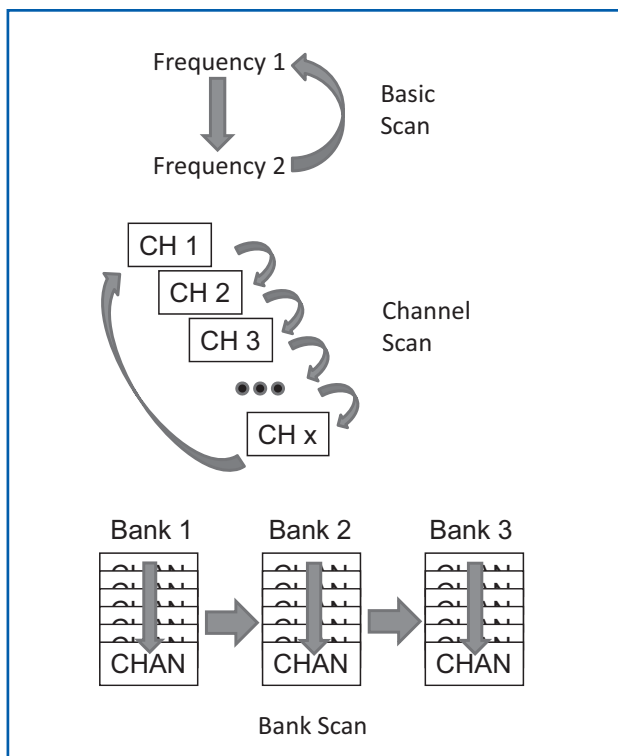

Figure 7 — Radios on the market today can rapidly switch from frequency to frequency to look for signals. This is called *scanning*. This allows the operator to monitor many different frequencies without having to manually tune to each one. There are three types of scanning (see text).

Scanning

Radios on the market today can rapidly switch from frequency to frequency to look for signals. This is called *scanning*. It allows the operator to monitor many different frequencies without having to manually tune to each one.

There are three types of scanning. Basic scanning consists of the receiver starting from the *scan start* frequency and tuning continuously to the *scan stop* frequency. If a signal is detected, scanning is stopped or paused for the operator to listen in. This is most useful in the VHF and UHF bands and when listening for simplex FM signals.

Channel scanning is jumping from channel to channel in sequence. Again, scanning stops or pauses when a signal is detected. Channel scanning requires a *start channel* and a *stop channel*. Channels may be designated to be skipped, as well. This type of scanning is the most useful for watching many repeater or simplex channels.

Groups of channels may be organized in *banks*. *Bank scanning* scans all the channels in a bank before moving to the next bank. Not all radios organize their memory channels as banks. Banks are useful for grouping channels together by function; police, fire, aircraft, ham, etc.

Programmed scan is the most flexible of all and allows the user to set up lists of channels to be scanned. This is most conveniently done with a PC instead of the radio keypad. Channels can generally be scanned in any order. The PC software often allows the operator to set up “profiles” of programmed scans (for example, parade communication or ARES drills in which different sets of channels are in use) so that the radio can be configured quickly and efficiently.

Scanning is much more convenient to use if you have control over *scan delay* and *scan resume*. Scan delay is the time the radio spends listening to each channel before moving to the next one. A longer delay catches more activity and lets you listen longer to each channel, but slows down the overall scanning process. Scan resume tells the radio to how long to pause or to stop if a signal is detected. Some radios offer *voice detection* to distinguish between a voice signal and a steady tone or noise that may result from interference.

Antennas

Antenna choice is the single biggest factor in determining whether you’ll be able to communicate effectively with any type of radio. Handheld radios come with a stubby, flexible antenna (“rubber duck”) that attaches directly to the radio for convenience. These are fairly sturdy, but are not very efficient. Consider purchasing a more efficient mobile *whip* antenna with the necessary connector or adaptor for your radio. At home you can attach a mobile antenna to a metal surface or structure. Longer, more efficient antennas to replace the rubber duck are also available. For repeater and FM voice communication, the antenna should be oriented vertically (“vertically polarized”) to match the signals from repeaters and other hams.

Mobile antennas are mounted on the outside of a car. Temporary mounts using magnets

(*mag-mounts*) or clamps (*lip-, trunk-, mirror-mount, etc*) and permanent through-the-body mounts provide a *ground-plane* for the antenna. You can purchase the complete antenna system, including the whip, mount, and cable or you can purchase a separate mount with cable. Antennas attach to the mount by one of several different methods: a threaded base, PL-259/SO-239, and NMO are the most common. Your antenna will need to match the mount. An *on-glass* antenna does not need the metal ground plane, using an adhesive pad to attach to the vehicle's window, but is usually less efficient and may not work with some types of auto glass.

Antennas are generally rated in terms of *gain* – how well they concentrate signals in a preferred direction. Gain is specified in *dB* and every 3 dB of gain doubles your signal's strength. An *omnidirectional* antenna or “omni” radiates equally well in all horizontal directions and can be used with base, mobile, and handheld radios. The gain of an omni antenna concentrates the signal towards the horizon.

At home, you may want to install a permanent antenna such as the common ground-plane antenna with three or four radials. Mounted in the clear, a ground-plane will give good performance. The *J-pole* antenna operates similarly to the ground-plane, but does not require radials. *Collinear* antennas with several sections working together look like ground-planes, but are longer and have higher gain. A *Yagi* antenna is a type of rotatable *beam* antenna that has gain in one direction and is used to communicate with stations that are out of range of simple omnidirectional antennas. A *rotator* is needed to point a beam in the desired direction.

If you purchase an antenna without the connecting *feed line*, use a high-quality cable that has low losses at VHF and UHF frequencies. (All cables have increasing loss with frequency.) For distances shorter than 50 feet, RG-8 or RG-213 are fine. At 2 meters, RG-8X can be used up to 50 feet, but no longer than 25 feet at 70 cm. You won't need ultra-low-loss “hard-line” or specialty cables to get started. For longer “runs” of cable, ask for help from your Elmer, from a radio store, or from the manufacturer's specifications to choose the right cable. While cables are available with connectors pre-installed, you should eventually

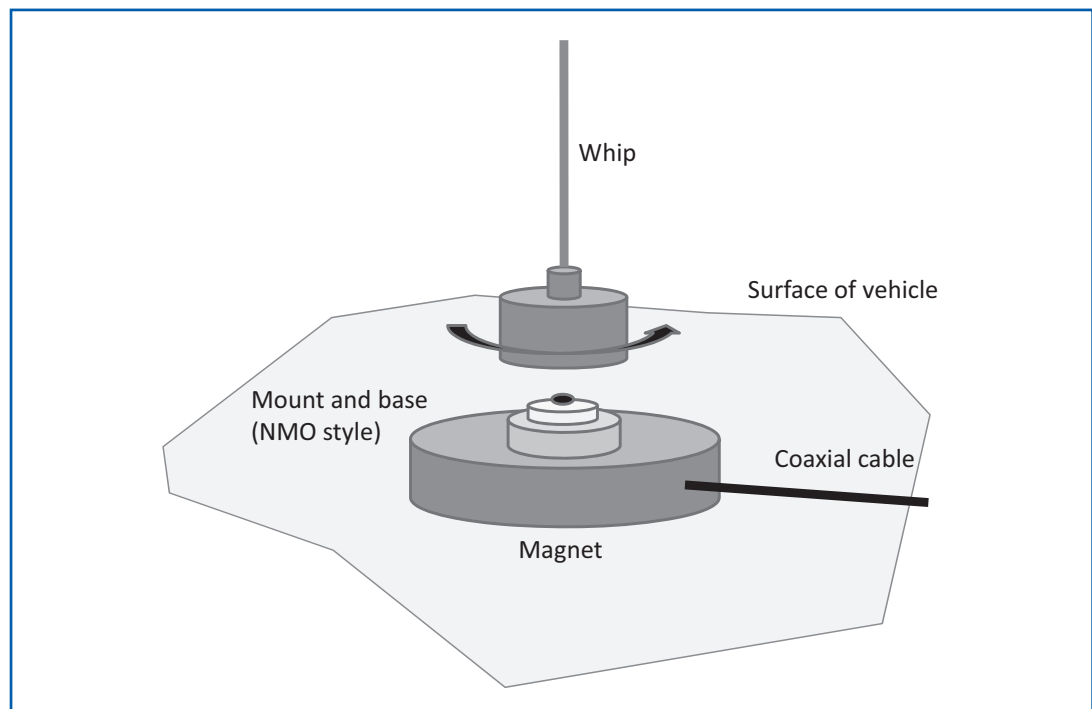

Figure 8 – One popular type of temporary mobile antenna mount uses magnets and is often referred to as a *mag-mount*.

learn how to install your own connectors—both to have the skill and to save money! The ARRL's online Technical Information Service www.arrl.org/tis/ and the *ARRL Antenna Book* and *ARRL Handbook* contain methods of installing connectors on coaxial cable.

Accessories & Special Features

Along with the items included with your radio, other common accessories can be a great help in the convenient and effective use of your radio. The most important accessory for a mobile radio is the antenna—we covered that previously. For a handheld radio, antennas and batteries make the most difference.

- *Battery chargers*—Recharging a battery with a wall wart supply can take hours for one of the larger packs. This is often unacceptably long and is a good argument for having a spare battery pack. Charging time can be reduced dramatically by using a *quick charger* or *smart charger*. Your radio's manufacturer will probably offer one as an accessory. A desk or “drop-in” charger holds the radio conveniently upright while charging, too.

- *Detachable front panels*—Some radios can operate with their front panel detached from the body of the radio and mounted in a convenient location with the radio out of sight below a desk or seat. An accessory *control cable* is required to connect them. Some radios require the microphone to be connected to the radio and not the control panel, so check carefully before planning where to mount the radio!

- *Smart microphones*—Handheld microphones or *hand mikes* for mobile and base radios are available with enough keys and buttons to act as miniature front panels of their own. There may be several variations of microphones available for your radio.

- *Headsets*—Base station radios come with a hand mike, but third-party desk microphones and headphone-boom microphone combinations called *boomsets* may be more convenient and provide somewhat higher quality transmitted audio. Headphones can help you hear other stations more clearly, particularly in noisy environments such as a busy emergency-operations center or an outdoor event. (Driving with a headset or headphones on is illegal in many areas—check your local regulations.)

- To tune your antenna, an *SWR bridge* or *RF power meter* is a “nice-to-have”, measuring the amount of power flowing to and from the antenna. By watching the meter when you transmit, you can tell when an antenna is not tuned properly, whether the wrong antenna has been attached, or whether some part of the antenna system is broken. Be sure the bridge or meter is designed for the frequency you'll be using—VHF/UHF or HF.

PROGRAMMING AND CONFIGURATION SOFTWARE

With so many memory channels and radio configuration settings to manage, having some software to assist you is very useful. Programming and configuration software is available from the radio manufacturer and from independent authors. Along with the software, you'll need a programming cable to connect the radio to the computer. *Cloning* is another way of configuring your radio by transferring the memory contents from an identical radio. If your radio supports cloning, a special cable is usually required. Your club or emcomm team may have cables and software for common radios, including files that will program your radio with the common channels used by members.

HF EQUIPMENT

The HF or “short-wave bands” are important because of their long-range capability. When HF conditions are favorable, contacts around the world are possible without the need for repeaters or the use of Internet-based systems, such as IRLP or Echolink. The traditional amateur HF bands include 160, 80, 40, 15 and 10 meters (1.8 MHz to 29.7 MHz). In the early 1980s, the 30, 17 and 12 meter bands (10, 18, and 24 MHz) were added and are sometimes referred to as the “WARC” bands (in reference to the World Administrative Radio Conference at which frequencies are allocated). The 60 meter band (5.5 MHz) was added more recently.

Many models of transceivers are available for the HF bands from portable, mobile and fixed stations. There is also a wider price range than for VHF and UHF radios. As you look through the catalogs, you’ll see large radios and small radios with much the same specifications—this section will help you understand the real differences.

Portable radios are designed to be compact, lightweight and power-efficient. They are available with power outputs of 5 to 100 watts and cover all of the HF bands—some even operate on VHF and UHF bands. Low-power models may have an internal battery pack. They have fewer features than most fixed-station radios and receiver performance is

generally not as good. Their smaller front panels mean they have fewer controls and often use menus for some functions.

Mobile radios are intended to be operated in a vehicle, but they can make an excellent base-station radio, especially if you have limited space. These radios consume somewhat less current than fixed station radios when not transmitting. This may be important if you intend to use the radio for emcomm and expect to be operating on battery power occasionally. If not used in a vehicle, a dc power supply will be needed. The same concerns about small front panels and ease of use apply.

Radios for base stations are available in many different price ranges because of the great differences in performance and features. Some will operate directly from ac power outlets. Most of the performance differences are associated with the receiver. High-performance receivers have better *selectivity* and *strong-signal performance* as discussed later. Some radios even have two receivers! It is normally best to start with a basic radio and develop a feel for what is important to you.



The ICOM IC-7000 transceiver.



The Yaesu FT-897 transceiver.

HF GLOSSARY

- All-mode:** radio that can operate on AM, SSB, CW, Digital, and FM
- Attenuate (attenuation):** reduce in strength
- Balun:** stands for “balanced-to-unbalanced”, provides a transition from parallel wire feed lines or antennas to coaxial feed lines.
- Beam:** antenna with gain primarily in one direction
- Crystal filter:** filters that use quartz crystals to reject unwanted signals in receivers
- CW (continuous wave):** Morse Code
- dB (decibels):** logarithmic method of comparing two signal strengths (power, voltage, current)
- Data interface:** a device for connecting a computer to a radio
- Digital mode:** communication method that exchanges characters instead of voice or Morse Code
- Dipole:** a simple wire antenna 1/2-wavelength long with feed line attached in the middle
- Directional wattmeter:** a wattmeter that can measure power flowing in both directions
- Emcomm:** abbreviation for “emergency communications”
- Feed line (transmission line):** cable used to transfer radio-frequency energy
- Gain (antenna):** antenna’s ability to receive or transmit energy in a preferred direction
- Ground plane:** (1) conductive surface that acts as an electrical mirror; (2) an antenna that requires a ground plane to create an electrical image
- Half-wave:** 1/2 wavelength
- HF:** High Frequency (3 MHz to 30 MHz)
- Impedance:** a measure of how easily power can be transferred into a load or through a feed line
- Keyer:** an electronic device that generates Morse code elements.
- Linear:** an amplifier that boosts the power output from a radio without distorting the signal
- Menu:** list of selectable control or configuration functions or options to select from
- Overload:** a signal so strong that circuits begin to operate improperly
- Paddle:** used with a keyer to send Morse code
- Power supply:** device that changes ac power into dc power
- QRP:** very low-power operating (less than 5 watts on CW and 10 watts (peak) on phone)
- Quarter-wave:** 1/4 wavelength
- Range:** distance over which communication can take place
- Scanning:** monitor a range of frequencies or a set of memory channels for activity
- Screwdriver:** a tunable mobile whip, refers to electric screwdriver motors used on early models
- Selectivity:** a receiver’s ability to receive only the desired signal and reject all others
- Sensitivity:** a receiver’s ability to detect weak signals
- Signal-to-noise ratio:** a comparison of a signal’s strength compared to background noise
- Strong-signal performance:** the ability to withstand overload and distortion from strong signal
- SWR:** Standing Wave Ratio, indicates how much power is transferred to a load or antenna
- VFO:** Variable Frequency Oscillator, refers to a radio’s continuous tuning mechanism
- WARC:** World Administrative Radio Conference at which frequency allocations are determined
- Weak-signal:** making long-distance SSB and CW contacts with low signal-to-noise ratios
- Whip:** antenna made from a long, thin metal rod

Frequencies and Modes

Commercially available HF transceivers cover all of the amateur bands described in the introduction to this section. Some add the 6 meter band from 50 – 54 MHz and even VHF/UHF bands from 2 meters to 23 cm (1.2 GHz). These radios are “all-mode”, using AM, SSB, CW, FM, and digital modes. You can use these radios for everything from contacts on your local repeater to long-distance contacts on the HF bands where SSB and CW are the most popular modes. The *ARRL Operating Manual* discusses the characteristics of the different HF and VHF/UHF bands.

The longer wavelength HF bands (160 – 30 meters) are generally used for local and regional contacts through the day, but support long-distance (*DX*) contacts at night. Shorter wavelength bands (20 – 10 meters) “open” and provide long-distance contacts through the day, but “close” at night when the signals are no longer reflected back to Earth by the ionosphere.

The VHF and UHF bands support line-of-sight regional contacts and long-distance contacts via several interesting means of propagation. This is called *weak-signal* operating and is conducted on 50, 144, and 432 MHz mostly using SSB and CW because those modes work better at low *signal-to-noise ratios*, while FM requires stronger signals to be effective.

While able to transmit only in the ham bands, HF radios typically include *general coverage* receivers that can tune from a few hundred kHz to 30 MHz. (*Medium wave (MW)* stations use frequencies from 300 kHz – 3 MHz and *long wave (LW)* below 300 kHz.) *Ham band only* receivers don’t offer this coverage. *Wideband receive* coverage extends above 30 MHz into the VHF and UHF range. The Wikipedia entry on “shortwave” (en.wikipedia.org/wiki/Shortwave) will give you an idea of what you can listen to. The VHF/UHF section on frequency coverage will help you decide if wideband receive is useful for you.

Power – Input and Output

Transmitter output power of HF transceivers ranges from 100 to 200 watts with most between 100 and 150 watts. The extra power will not make a dramatic difference on the air, however. Power amplifiers (a.k.a. – *linears* or *linear amplifiers*) are available to increase the output power to 600 to 1500 watts (maximum legal power for hams) for more demanding conditions and activities.

Beginning HF operators will have the most success using power levels around 100 watts.



The Kenwood TS-2000 transceiver.

Running “barefoot” (without an amplifier) with a modest antenna is often sufficient for lots of contacts, including world-wide DX during favorable conditions. More power, provided by an amplifier, will extend your transmit range and enable you to maintain contact longer as conditions change, but adds significant expense and raises the demands placed on station equipment. Lower power, or *QRP* operating, is something you can try as you gain experience, turning the radio’s output power down whenever you’d like to give it a try!

A radio with a built-in ac power supply does not need an external dc supply. Most radios do require an external dc supply, though. Be sure to select a power supply that is rated to continuously provide the maximum current specified in the radio’s manual. Because most radio accessories operate from the same voltage as the radio (13.8 V for most “12 V” radios) it is wise to add a few more amperes of current output to power them. For example, if a radio requires 24 amps at full power, choose a supply that can deliver 30 amps or more.

Filters & Receiver Performance

The HF bands are a challenging environment for receivers; signal strengths vary from barely detectable to extremely strong. The bands are often crowded with strong signals. The most important receiver characteristics are *selectivity* (the ability to reject unwanted signals) and *strong-signal performance*.

Selectivity is created by filters with different bandwidths suited to the signal’s mode. You’ll encounter radios that use discrete electronic *crystal filters* and software-based *DSP (Digital Signal Processing) filters*. HF radios that use discrete filters will come with a medium-bandwidth filter for SSB (about 2 kHz), an AM filter (6 kHz), and an FM filter (15 kHz). A CW filter (500 Hz) or RTTY filter (250-300 Hz) are needed if you expect to use those modes a lot. Filters can be added after you purchase the radio.

DSP filters are created by software in the radio’s controlling microprocessors, reducing or eliminating the need for separate electronic filters. The radio will come pre-programmed with several common filter types. You can create new filter types and even adjust them while you are using the radio.

The radio’s ability to operate properly in the presence of strong signals is measured primarily in two ways; *blocking dynamic range (BDR)* and *3rd-order intercept point (TOI)*. In both cases, higher figures are better. BDR in decibels (dB) describes the receiver’s ability to ignore unwanted signals. TOI in dBm (a power level) describes the receiver’s reaction



To operate a 100-watt transceiver, you need a power supply that can provide the necessary current, typically 30 amps or more.

to multiple strong signals. A difference of 6 dB or more represents a noticeable change in performance. While commercial transceivers have adequate strong-signal performance, the more you expect to operate on HF, the more important these figures will become. The ARRL's *Product Reviews* are a valuable source of information about receiver performance and are free to ARRL members on the ARRL Web site and in *QST* magazine.

Four other features help a receiver reject interference and other unwanted signals. Having these controls on the front panel is very useful when operating on a crowded band.

Receive Incremental Tuning (RIT), sometimes called "Clarifier", changes the receive frequency without moving the transmit signal. *Passband tuning* or *passband shift*, controls where the receiver's filters are tuned relative to the main receive frequency. This allows you to reduce off-frequency interference without changing the receiver's main tuning frequency.

Notch filters can reduce interference appearing as continuous tones, not uncommon on the HF bands, created by unwanted signals or commercial broadcast stations. A notch filter removes a very narrow slice of the audio range that can be adjusted to match the tone of the interference. This either eliminates the tone or reduces it to a tolerable level.

A *noise blanker* suppresses *impulse noise* created by motors and vehicle ignition systems.

Digital Signal Processing

Many new radios employ *Digital Signal Processing (DSP)* to perform many functions in software that were previously performed by electronic circuits. Special microprocessors do the job inside the radio. The latest generation of radios using DSP has very good performance. DSP filtering was discussed in the preceding section.

DSP is also employed to get rid of unwanted noise. *Noise reduction (NR)* is used to reduce the hissing and crackling of static and other random noise present in the audio of received SSB and CW signals. This function is usually available with several levels of

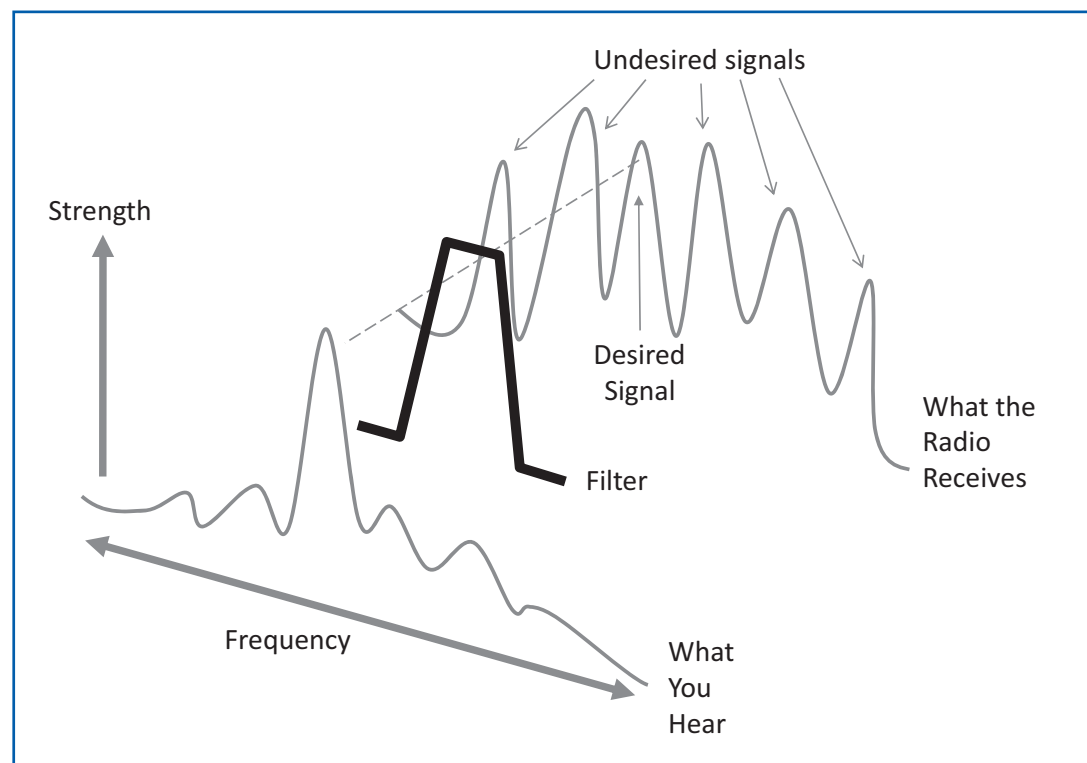

Figure 9 — Selectivity is created by filters with different bandwidths suited to the signal's mode.

processing, with more aggressive levels also giving the signals a “digital” sound. *Noise blanking (NB)* is used to remove repetitive noise pulses, such as those from an automobile’s ignition system or power-line noise from nearby ac utility lines. Noise blanking is very useful in mobile HF radios and noise reduction can be used for all SSB and CW HF operating.

DSP can also be used to create a notch filter. Not only can the filter’s notch frequency be manually adjusted, just like an electronic notch filter, but many DSP notch filters can automatically detect the frequency of the interfering tone and tune the notch filter (*Automatic Notch Filter* or *ANF*). Some radios even have the ability to “notch out” more than one tone at a time!

Radios with more DSP functions also allow you to control the *filter response*—how aggressively nearby signals are rejected. A filter that allows some of those signals to be heard has a “soft” response, while one that rejects the signals more completely is “sharp” or “steep”. Soft filters result in more natural sounding audio, but do not reject interfering signals as well. If the DSP functions are also applied to the output signal, you may also be able to tailor your transmitted audio to suit your voice, adding more average power and increasing the intelligibility of your signal.

Memories

HF transceivers use memories and VFOs in much the same way that VHF/UHF models do. Start by reading the VHF/UHF section on memories. HF radios often offer *band memories* as well, sometimes referred to as *band-stacking registers*. These memories store one to several settings of the VFO on each of the HF bands. Pressing a band-select key on the radio’s front panel cycles through these memories. This is useful if you use the same frequency on a regular basis.

Scratchpad memory is a set of temporary memories for use when you are just tuning around the bands and want to save a frequency and mode setting without dedicating a memory. Like VHF/UHF radio memories, the memories store not just the frequency, but also the mode, filter and other settings.

To find out how many memories you’ll want on your HF radio, count all the nets and emergency frequencies you might use, some of the frequencies for WWV and WWVH (www.nist.gov—the US time and frequency standard stations), calling frequencies for your most-used modes, propagation beacons, and any other frequencies of interest. Add some extra memories for expansion.

Scanning

Scanning is also provided in mid- to top-scale HF radios, just as in the VHF/UHF radios (read the VHF/UHF scanning section for a discussion of the terms). The most popular scanning mode on HF is *range scanning* in which the radio tunes continuously across a portion of the band, looking for any signal. Scanning is less useful on HF, however, because of the higher noise levels and the wider range of usable signals, making it difficult to set a single level to use as the scanning threshold.

Antennas

If antennas are the most important part of an amateur station, that is doubly true on HF where long-distance contacts place a premium on the antenna’s ability to transmit and receive efficiently. Antennas are generally rated in terms of *gain*—how well they concentrate signals in a preferred direction. Gain is specified in *dB* and every 3 dB of gain doubles your signal’s strength.

The simplest antenna (and a very effective one) is a *half-wave dipole* made of wire, one-half wavelength long, and installed horizontally. You can build it yourself as de-

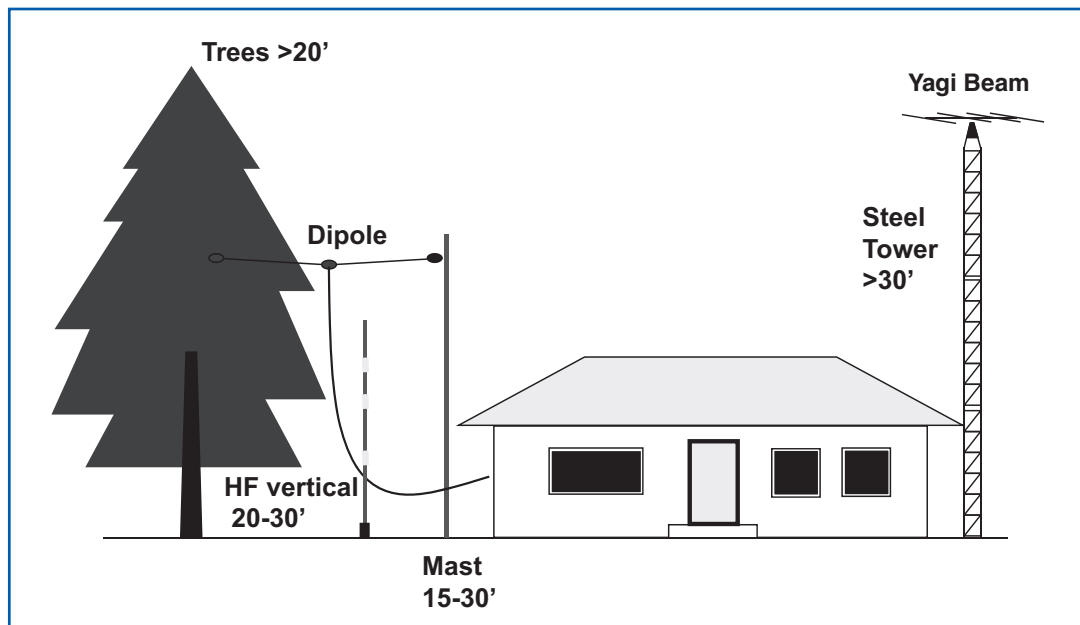

Figure 10 – You have many antenna options to choose from, depending on your budget and how much space you have available.

scribed on the ARRL’s Technical Information Service (TIS) Web page or you can buy one or any of several common variations; off-center-fed, multi-wire, and G5RV antennas are popular. While a dipole’s gain is low, it’s efficient and hard to beat for the price. You’ll need one or two supports (trees work well) at least 20 feet tall. Large-scale versions of the Yagi beam antennas mentioned in the VHF/UHF section can be placed atop steel towers, although this is not required to get started.

Vertical antennas are also popular, particularly where a horizontal antenna may be difficult to put up, for portable use, and where a “low profile” antenna will be more suitable. The simplest is a *quarter-wave vertical* made of metal tubing and *radial wires* fanning out from the base to act as a ground plane. To use it on several of the HF bands will require an *antenna tuner* described in the next section. *Multi-band verticals* are constructed to operate on several bands without the antenna tuner. *Ground-independent verticals* are available that operate without the radial wires.

Mobile antennas for HF use come in two common styles; fixed-tuned and tunable whips. A fixed-tuned whip is adjusted to present the proper load to the transmitter on one band or over a portion of a band. You will need one for each band you intend to use, but they are inexpensive. The whips have a 3/8”-24 threaded base that screws in to the antenna mount on the vehicle, similarly to what is shown in the VHF/UHF section. A tunable whip with an internal coil (called a “screwdriver” antenna) can vary its length continuously to tune up on nearly any HF frequency. A controller is mounted in the vehicle. Only one tunable whip is required, although they are much more expensive than the fixed-tune whips.

Mobile antennas can be mounted on the vehicle temporarily or permanently. A permanent mount generally results in a better electrical ground connection to the vehicle, which is important for the HF antennas to work well. Temporary mounts, such as larger versions of the VHF/UHF *magnet* or *mag-mounts*, are usable for most purposes



The High Sierra HS-1800 is a so-called “screwdriver” style HF mobile antenna that provides continuous coverage for all HF bands.

but have lower efficiency than mounts attached directly to the vehicle and can be knocked loose. If you purchase the mount separately from the antenna, make sure the mount and antenna have the same type of mechanical connection!

The most popular antenna feed line is *coaxial cable* or *coax*. There are many types, but the most common are (from smallest to largest) are RG-58, RG-8X, and RG-8 or RG-213. Use RG-58 only for short (50 feet or less) distances due to its higher losses and never at the output of an amplifier. RG-8X will carry the full legal power, but is not a good choice for feed lines longer than 100 feet or mistuned antennas. RG-213 is suitable for all amateur HF uses, except for extremely long feed lines. At HF, the standard connectors are the “UHF” connector family’s PL-259 (cable plug) and SO-239 (equipment receptacle) illustrated in the VHF section. Cable is available with connectors pre-installed or with a little “Elmering” you can learn how to install them yourself as described on the ARRL TIS Web site.

The other type of feed line is *open-wire, ladder, or window line* consisting of two parallel wires coated with plastic insulation. Open-wire line has very low losses, but is not as convenient to use as coaxial cable and requires an antenna tuner or some other kind of *impedance transformer* to work with most HF radios along with a parallel-to-coaxial *balun* so that you can connect the feed line to the radio.

Accessories & Special Features

Antenna tuners are known by several names; *impedance matching unit, tuning unit, matchbox, transmatch*, etc. They do not actually tune the antenna, but convert whatever impedance is presented by the antenna system at the input to the feed line into a 50-ohm load so that your transmitter will deliver maximum power output. Some radios have an automatic antenna tuner or ATU built-in, but if yours doesn’t and your antenna’s SWR is much higher than 2:1 on a frequency you wish to use, then you’ll need an external antenna tuner, either automatic or manually-adjusted. A model rated at 300 watts will accommodate the output of a 100-watt transceiver with room to spare. Manual antenna tuners often include an *SWR meter* or *directional wattmeter*, but these can also be purchased as individual items and are very handy shack accessories. An SWR meter can be used as an antenna system test instrument or to monitor the state of an antenna. Directional wattmeters measure the power flowing back and forth in your feed line and may also be calibrated to show SWR. Both power and SWR meters are designed to be used at either HF or VHF and will provide uncalibrated read-



Two so-called “UHF” (PL-259) coaxial

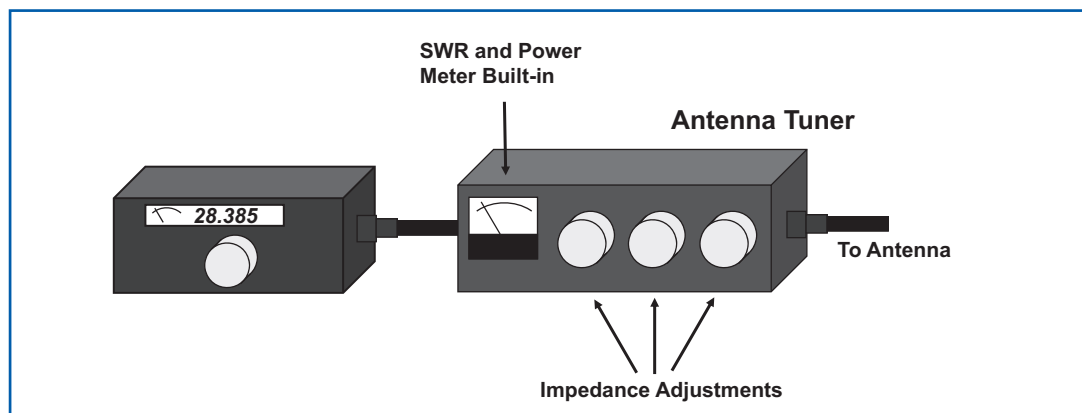

Figure 11 — *Antenna tuners* are known by several names; *impedance matching unit, tuning unit, matchbox, transmatch*, etc. They convert whatever impedance is presented by the antenna system at the input to the feed line into a 50-ohm load so that your transmitter will deliver maximum power output.



Some transceivers include the ability to separate the front panel (the “control head”) from the rest of the unit for easier mobile installations.

ings at other frequencies.

Antenna switches allow you to select different antennas quickly. The “common” port of the switch connects to the output of the radio or antenna tuner with a short *jumper* of coax and the antenna system coaxial cables then connects to the selectable ports of the switch. Some radios have an antenna switch built-in. As long as we’re on the subject, it’s useful for an HF transceiver to have a receive antenna (RX ANT) input for a special receiving antennas or external filters.

All manufacturers offer separate speakers for their radios that sound somewhat better than the radio’s small built-in speakers. For the highest quality “copy” of signals, though, use a pair of headphones. A set intended for music will do or you can buy headphones designed specifically for radio communication. A *boom-set* is headphones combined with a *boom microphone*. The boom mike frees you from having to hold a hand mike or speak into a desk microphone. The voice-operated transmit (VOX) option of most radios frees your hands from having to press a Push-to-Talk (PTT) switch.

Computer Interfaces

What if you want to make digital mode contacts using a PC or just control the rig from the PC keyboard? There are several software packages available and some are even free! There are three types of computer interface connections to ham radios.

The first is a *control port* by which a PC can read, change, and operate many, if not all, of the radio’s control functions. This allows a PC to monitor and record your radio’s configuration for logging contacts and other useful functions. Radios “speak” a control protocol that is unique to each manufacturer. Most radio control ports are a serial or COM port for communicating with the PC. (Icom radios use a proprietary CI-V interface.) PC manufacturers are dropping the COM or serial port, but USB-to-serial port converters are available to solve that problem.

The second type are called *keying interfaces* or *voice keyers* that allow the PC to key the radio (to send CW) from the keyboard or send recorded speech through the microphone jack. These are often used during competitive events called *contests* or *radiosport*.

The third type of interface supports digital modes, such as radio-teletype (RTTY) or PACTOR, the mode used by the ham radio email



A headset/microphone combination, or *boomset*, combines the microphone and earphones in one unit.

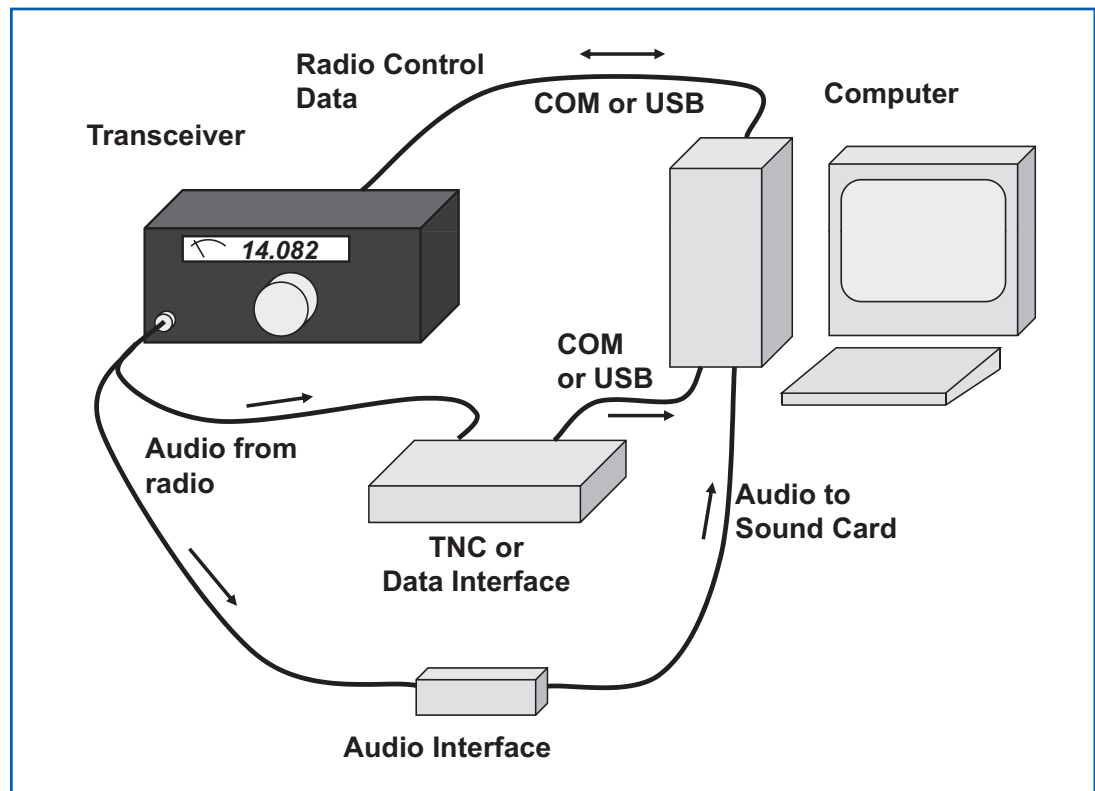

Figure 12 – With the right hardware and software, you can use your computer to control your transceiver and even make contacts using a variety of digital operating modes.

network known as Winlink. The computer's sound card is connected to the microphone and headphone jacks through a *data interface*, available from several manufacturers. These devices *isolate* the radio's input from the sound card's output, preventing hum, RF feedback, and other problems. If your radio has a *data port*, the computer can send and receive data directly from the radio without using audio to or from your sound card. Interface cables are usually available for specific radios from the interface manufacturer.

MANUFACTURER'S DIRECTORY

These are the Web sites for the primary manufacturers of Amateur Radio transceivers:

Alinco	www.alinco.com
Elecraft	www.elecraft.com
FlexRadio Systems	www.flex-radio.com
ICOM	www.icomamerica.com
Kenwood	www.kenwoodusa.com
MFJ Enterprises	www.mfjenterprises.com
Ten-Tec	www.tentec.com
Yaesu	www.yaesu.com

Many other manufacturers and distributors are listed in the pages of *QST* magazine and in the ARRL Technical Information Service directory at www.arrl.org/tis.